

# DDU 210

Dashboard - TFT color display

## Description

The DDU 210 is a combined dashboard and input module for use either as a stand-alone display unit, or as an integral part of a complete data acquisition and monitoring system for use in the demanding environment found in motorsports vehicles.

The DDU 210 is equipped with a comprehensive range of analogue and digital inputs and ten-page liquid crystal display with configurable windows for an easily configured and personalised screen layout. The graphical bar indicator is typically used for representing engine revs.

As part of the Magneti Marelli data acquisition and telemetry system, the DDU 210 can communicate over a CAN network with a range of data loggers receiving and displaying data from the logger as well functioning as an additional input module.

It is also available a version (DDU 310-DL64/128) with internal data logger (64 or 128 Mbyte).

## Main Features

- 5 Single-ended
- 1 Pick-ups or Hall effect
- 3 Hall effect
- 2-axis internal accelerometer,  $\pm 10$  g
- Page and channel name labels
- Transmit internal diagnostic over CAN bus
- 48 alarm channels with programmable thresholds
- Display dedicated to 48 internal channels
- Lap time message displayed on dedicated page
- PC interface via Ethernet for loading graphical layout
- Easy to use and configure by Axon tool
- Designed for rugged applications

## Benefits

- TFT 6.2" transfective dot matrix color display
- 240 x 640 pixel resolution
- Graphical engine revolution counter with configurable non-linear scale
- Alarm condition displays channel name and value (with priorities for multiple alarms)
- Backlight regulation (8 steps)
- Inputs configurable to suit all sensors in the product range
- 2 push-button on the front panel for page selection, alarm level set, rpm/speed conversions, message hold time
- 6 high-brightness warning lights yellow/red for gear change (with programmable threshold) and 2 blue for general alarm condition indication
- 2 outputs for external warning lamps with short-circuit protections
- Floating point data management



## Typical Applications

- MotoGP
- Professional circuit and rally applications
- One make race series
- Race motorcycle application
- Touring car

# DATA DISPLAY

## DDU 210

Dashboard - TFT color display

### Technical Characteristics

#### Inputs

Single-ended	5
NTC/PT1000 temperature sensor	2
NTC internal temperature sensor	1
2-axis internal accelerometer ( $\pm 10$ g)	1
VR Pick-ups or Hall effect (RPM)	1
Hall effect (wheel speed)	3
On/Off digital (page scroll and confirm)	2
Lap Trigger	2
"Code Load" enable pin	1

#### Outputs

Voltage references (@ 5 V)	1
Low-side (@ 12 V)	2
Shift Lamp (adjustable brightness)	6
Alarm (adjustable brightness)	2

#### Communications

CAN line (1 Mbit/s (*))	2
Ethernet line (10/100base T)	1
RS232	1

(\* ) Configurable on request

#### Logic Core

Microcontroller A (80 MIPS RISC)	1	Kbyte
Microcontroller B (64 MIPS RISC)	1	Mbyte
FPGA (50k gates)	1	
Graphic display controller	1	
DPR	32	Kbyte
Flash E2PROM (microcontroller A)	1	Mbyte
RAM memory (microcontroller A)	48	Kbyte
Flash memory (microcontroller B)	512	Kbyte
Ram memory (microcontroller B)	4	Kbyte
Flash NV Ram	32	Mbyte
RAM memory	512	Kbyte
E2PROM	32	Kbyte
Time keeper	1	

#### Other Characteristics

Power supply	10 to 18	V
Operating internal temperature	0 to 60	°C
Protection class	IP 65	
Transflective dot matrix color display	TFT 6.2"	

#### Dimensions

without connector	188 x 110 x 34.4	mm
with connector	188 x 110 x 59.2	mm
Weight (approx.)	580	g

### Dimensions

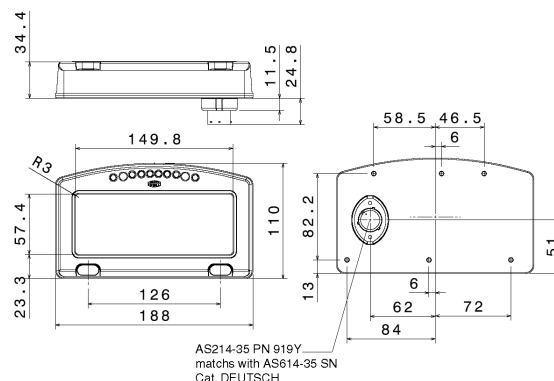

Dimensions in millimetres

### Application Schematics

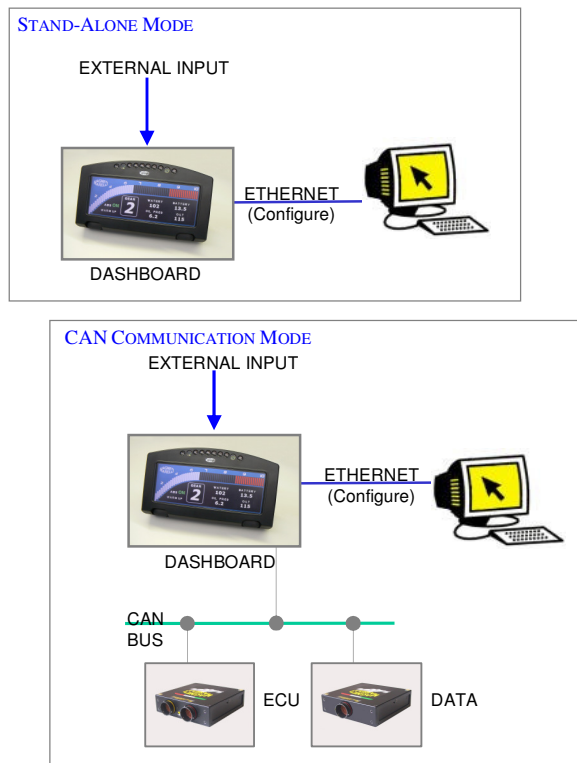

For further information, please contact:



**Magneti Marelli S.p.A.**  
Motorsport  
Viale Aldo Borletti, 61/63  
20011 Corbetta (Milano) Italy

Tel. +39 02 972 27 478  
Fax +39 02 972 27 570  
sales@magnetimarelli.com  
http://www.magnetimarelli.com

November 2009  
rel. 12  
page 2 of 2