

SDL

Racing Data Logger

Description

SDL is an evolution of Magneti Marelli successful HRDL-1 to increase logging performances (higher data throughput and logged channels number), the number of Inputs (to allow a flexible set up) and to reduce the dimensions and weight.

SDL is intended to enhance the new Magneti Marelli data logger product range, started with RDL.

SDL is a versatile data acquisition unit developed for racing applications which require high resolution data from a large number of channels.

Interconnection with the box can be obtained using two CAN lines, while the Ethernet line is dedicated to data download.

SDL is provided with analogue inputs including: Single-ended, differential, temperatures and K-type thermocouple.

Furthermore the device provides lap trigger and wheel speed inputs.

For further information or different solution, please contact our technical department.



Main Features

- 12 Single ended @ 12 bit resolution
- 4 Single ended @ 10 bit resolution
- 4 Differential @ 12 bit resolution (selectable gain: 1 or 100)
- 1 Pick-ups or Hall effect
- 4 Hall effect
- Up to 64 Mbyte logging memory
- Up to 300 logged channels
- Up to 40 kbyte/s logging rate
- Sampling rates up to 200 Hz
- 2 CAN communication buses
- 1 ARCNet line
- 1 Ethernet line

Benefits

- Data download via Ethernet link
- SW selectable NTC/PT1000 temperature sensor
- Floating point data management
- Direct management of Marelli dashboard display
- Pick-ups inputs for wheel speed and distance measurement
- Requires Wintax4 analysis software (compatible Win2K/XP/Vista 32 bit/7)
- Requires Axon logging setup tool
- Very compact design
- Robust design, easy to install

Typical Applications

Professional circuit and rally applications
 One make race series
 Industrial application
 Formula series

DATA LOGGER

SDL

Racing Data Logger

Technical Characteristics

Inputs

| | |
|--|----|
| Analogue Single-ended (@ 12 bit resolution)..... | 12 |
| Analogue Single-ended (@ 10 bit resolution)..... | 4 |
| Differential (*) (@ 12 bit resolution)..... | 4 |
| K-type thermocouple | 2 |
| NTC/PT1000 temperature sensor (selectable)..... | 4 |
| NTC internal temperature sensor..... | 1 |
| VR Pick-ups or Hall effect..... | 1 |
| Hall effect | 4 |
| Lap trigger (**)..... | 1 |
| "Code Load" enable pin | 1 |
| Syncro (Iso9141) | 1 |

(*) Selectable gain: 1 or 100
 (**) Configurable on request

Outputs

| | |
|--------------------------|---|
| Voltage references | 4 |
|--------------------------|---|

Communications

| | |
|----------------------------------|---|
| CAN line (1 Mbit/s (***))..... | 2 |
| Ethernet line (100 Mbit/s) | 1 |
| ARCNet line (10 Mbit/s)..... | 1 |
| RS 232..... | 1 |

(***) Configurable on request

Logic Core

| | |
|-------------------------------------|-----------|
| Microcontroller (80 MIPS RISC)..... | 1 |
| Flash E2PROM (microcontroller)..... | 1 Mbyte |
| RAM memory (microcontroller)..... | 48 Kbyte |
| RAM memory | 512 Kbyte |
| E2PROM..... | 4 Kbyte |
| Time keeper | 1 |

Logging

| | |
|-------------------------|------------------|
| Flash disk memory | 32 or 64 Mbyte |
| Logged channels | up to 300 |
| Logging rate | up to 40 Kbyte/s |
| Sampling rate | up to 200 Hz |

Other Characteristics

| | |
|--|-------------------|
| Power supply..... | 8 to 18 V |
| Operating temperature range (internal)..... | -40 to 85 °C |
| Temperature range during data download | 0 to 70 °C |
| Protection class..... | IP 54 |
| Dimensions | |
| without connector | 66 x 87 x 35.6 mm |
| Weight (approx.)..... | 230 g |

Dimensions

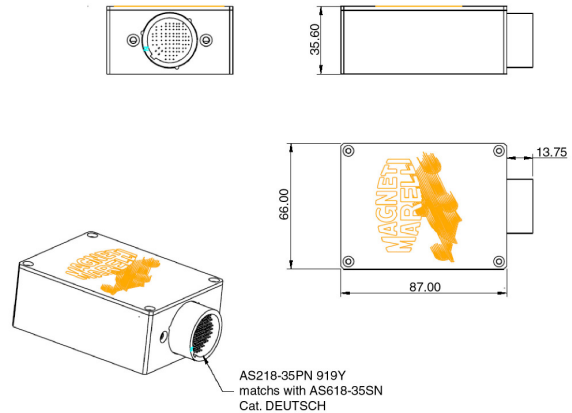

Dimensions in millimetres

Application Schematics

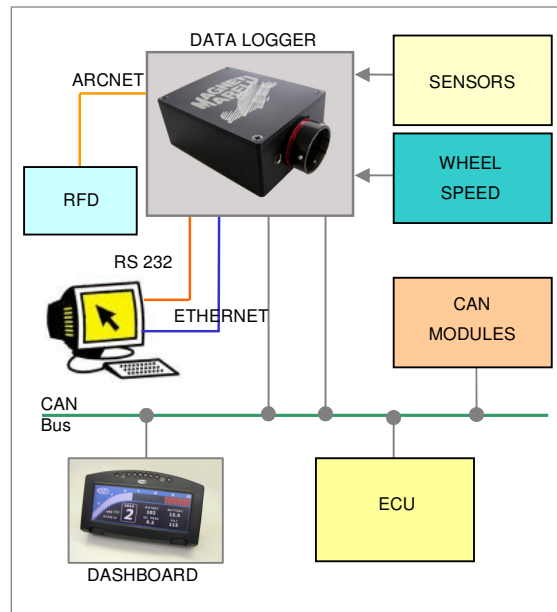

For further information, please contact:

SDL-0838XXXXXX00



Magneti Marelli S.p.A.
 Motorsport
 Viale Aldo Borletti, 61/63
 20011 Corbetta (Milano) Italy

Tel. +39 02 972 27 478
 Fax +39 02 972 27 570
 sales@magnetimarelli.com
 http://www.magnetimarelli.com

May 2011
 rel. 1
 page 2 of 2