

## ENGINE CONTROL UNIT

# MARVEL4

4 cylinders with double injection  
and internal data logger

### Description

MARVEL4 is dedicated to race applications that need high performances in a limited range of costs.

MARVEL4 is a modular design engine control system which includes an internal data logger.

It integrates two microprocessors and a DSP plus two FPGA to achieve great computation power. A very high speed Ethernet line is dedicated to data download, while an ARCNet line and two full CAN lines allow connections with others control devices.

It is compatible with a very wide range of actuators/sensors, especially F1 products, such as coils, injectors, and it's intended for universal installation from single up to 4 cylinders engine applications with double injection. It's possible to select overcurrent and feedback threshold according to the type of coils used.

Output stages provide also a double DC-motor control such as simple Drive by Wire or trumpets control. MARVEL4 is provided with some analogue inputs, all of them with 10 bit resolution, including integrated UEGO linear lambda with heater and knock controllers that provide full engine diagnostics and controls.

Note:

For different solution (e.g. 3 CAN lines, Lap trigger pulled down or pulled up, etc) contact our sale department.

### Main Features

- 17 Single-ended
- 3 Pick-ups or Hall effect
- 2 Hall effect
- 4 Inductive ignition drivers
- 8 On/Off injector drivers
- 2 H-Bridge: DC-Motor driver for "Drive by Wire" control
- 2 PWM
- 2 Linear Lambda sensor
- 2 Knock input for detonation control accelerometers
- 128 Mbyte internal data logger
- Up to 512 logged channels
- Up to 64 Kbyte/s logging rate
- Sampling rates up to 1000 Hz
- 2 CAN communication buses
- 1 ARCNet line
- 1 Ethernet line



### Benefits

- No need of external data logger
- Accurate engine control by means of high computation power
- Extremely reduce data download time by means of Ethernet link
- Compatible with F1 products (injectors, coils, sensors etc.)
- SW adjustable coil's overcurrent and feedback threshold
- SW selectable NTC/PT1000 temperature sensor
- Floating point data management
- Direct management of Marelli dashboard display
- Pick-up inputs for wheel speed and distance measurement
- Requires Wintax3 analysis software (compatible Win2K/XP)
- Requires Axon logging setup tool
- Very compact design and easy to install

### Typical Applications

MotoGP

Professional circuit and rally applications

# ENGINE CONTROL UNIT

## MARVEL4

4 cylinders with double injection and internal data logger

### Technical Characteristics

#### Inputs

Analogue Single-ended .....	17
Linear Lambda sensor .....	2
Knock sensor .....	2
K-type thermocouple .....	2
NTC/PT1000 temperature sensor (selectable) .....	6
NTC internal temperature sensor .....	1
V battery injector .....	1
VR Pick-ups or Hall effect (exclusive) .....	3
Hall effect .....	2
On/Off digital .....	1
Lap Trigger .....	1
"Code Load" enable pin .....	1

#### Outputs

On/Off injector drivers .....	8
Low-side On/Off .....	2
Inductive ignition drivers .....	4
H-Bridges .....	2
Lambda heater drivers .....	2
PWM .....	2
Voltage references .....	3

#### Communications

CAN line (1 Mbit/s (*)) .....	2
ARCNet line (10 Mbit/s) .....	1
Ethernet line (10/100 Mbit/s) .....	1
Serial current loop or RS 485 (exclusive) .....	1

\* Configurable on request

#### Logic Core

Microcontroller (40 MIPS RISC) .....	2
DSP (80 MFLOPS) .....	1
Dual port RAM (16 Kword) .....	1
FPGA (10k gates) .....	1
FPGA (100k gates) .....	1
Flash E2PROM (microcontroller) .....	2 x 512 Kbyte
RAM memory (microcontroller) .....	2 x 32 Kbyte
RAM memory (DSP) .....	512 Kbyte
Flash E2PROM .....	2 x 512 Kbyte
RAM memory .....	2 x 512 Kbyte
E2PROM .....	512 Kbyte
Time keeper .....	1

#### Logging

Flash disk memory .....	128 Mbyte
Logged channels .....	up to 512
Logging rate .....	up to 64 Kbyte/s
Sampling rate .....	up to 1000 Hz

#### Other Characteristics

Power supply	
total system operating .....	8 to 16 V
logic core operating .....	6 to 16 V
Operating temperature range (internal) .....	-20 to 85 °C
Protection class .....	IP 54
Dimensions	
without connectors .....	93 x 137 x 39.5 mm
Weight (approx.) .....	590 g

### Dimensions

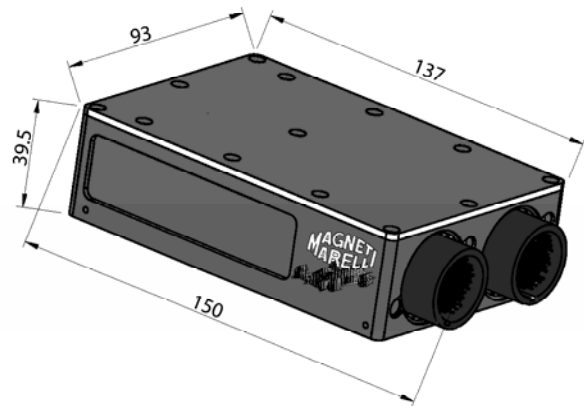

Dimensions in millimetres

### Application Schematics

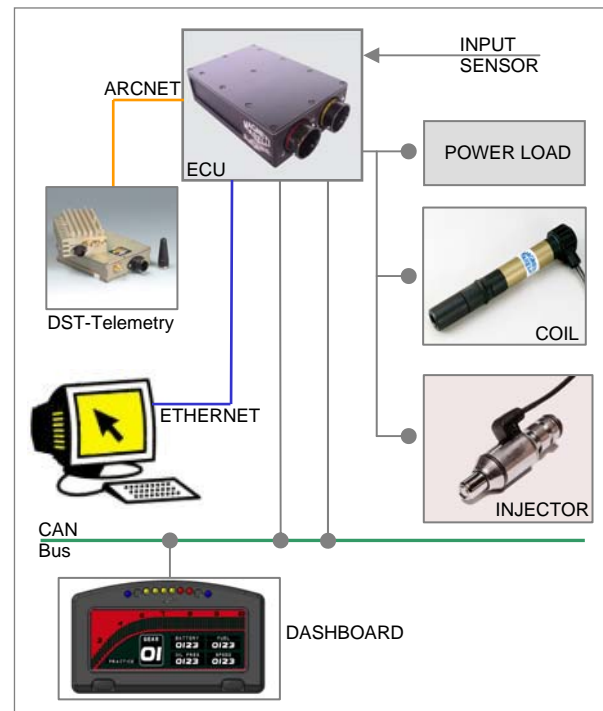

For further information, please contact:



**Magneti Marelli Holding S.p.A.**  
 Motorsport  
 Viale Aldo Borletti, 61/63  
 20011 Corbetta (Milano) Italy

Tel. +39 02 972 27 478  
 Fax +39 02 972 27 570  
 sales@magnetimarelli.com  
 http://www.magnetimarelli.com

October 2007  
 rel. 05  
 page 2 of 2