

ENGINE CONTROL UNIT

SRA-E

DBW control

High number of Inputs/Outputs

Ethernet line

Description

SRA-E is a dedicated Engine Control Unit. A single unit can drive up to eight injectors and six ignition coils. SRA-E can also drive logic command coils (SW option).

Communication from the PC based configuration tool and to other units (such as dashboard and logger) is by the 2 CAN lines and an asynchronous serial line.

Inside the unit there is a high performance RISC microcontroller and an FPGA for diagnostic purposes.

SRA-E provides analogue inputs for single-ended, temperature and knock-sensor as well as an interface for a switching lambda sensor. The unit also provides an H-Bridge output stage for use with suitable "Drive by Wire" actuators.

6 configurable speed sensor inputs (inductive or Hall) provide full flexibility of configuration for engine angle detection as well as other frequency inputs such as wheel or shaft speed.

SRA-EDL8/16 is a version of the SRA-E with an internal 8/16 Mbyte data logger.

SRA-E is supplied with the mating connector (loom side).



Main Features

- 8 Single-ended
- 6 Pick-ups or Hall effect
- 6 Inductive or logic command ignition drivers (SW option)
- 8 On/Off injector drivers
- 1 H-Bridge: DC-Motor driver for "Drive by Wire" control
- 4 PWM (Current controlled PWM)
- 1 On/Off or Linear Lambda sensor
- 2 Knock input for detonation control accelerometers
- 2 CAN communication buses
- 1 Ethernet line

Benefits

- Flexible setup by means of a high number of Inputs/Outputs
- The logic command coils option is available on request
- SW selectable NTC/PT1000 temperature sensors
- Floating point data management
- Direct management of Marelli dashboard display
- Compatible with a wide range of professional Marelli software tools
- Easy to install

Typical Applications

One make race series

ENGINE CONTROL UNIT

SRA-E

DBW control
High number of Inputs/Outputs
Ethernet line

Technical Characteristics

Inputs

Analogue Single-ended	8
On/Off or Linear Lambda sensor	1
Knock sensor (multiplexed).....	2
K-type thermocouple.....	2
NTC/PT1000 temperature sensor (selectable)	4
NTC internal temperature sensor	1
V battery injector.....	1
VR Pick-ups or Hall effect.....	6
On/Off digital.....	6
Lap Trigger.....	1
“Code Load” enable pin	1

Outputs

On/Off injector drivers.....	8
Inductive or logic command ignition drivers (SW option) ..	6
H-Bridges.....	1
Lambda heater drivers.....	1
PWM	4
Low-side On/Off.....	2
Voltage references.....	2

Communications

CAN line (1 Mbit/s (*)).....	2
Ethernet line (100 Mbit/s).....	1
Serial current loop.....	1

(*) Configurable on request

Logic Core

Microcontroller (80 MIPS RISC).....	1
FPGA (50k gates)	1
Flash E2PROM (microcontroller).....	1 Mbyte
RAM memory (microcontroller).....	48 Kbyte
RAM memory.....	512 Kbyte
E2PROM parallel.....	64 Kbyte
E2PROM serial.....	4 Kbyte
Time keeper	1

Other Characteristics

Power supply	6 to 16 V
Operating temperature range (internal)	-20 to 85 °C
Protection class.....	IP 65
Dimensions	
with connectors.....	208 x 182.30 x 42 mm
Weight (approx.)	960 g

Dimensions

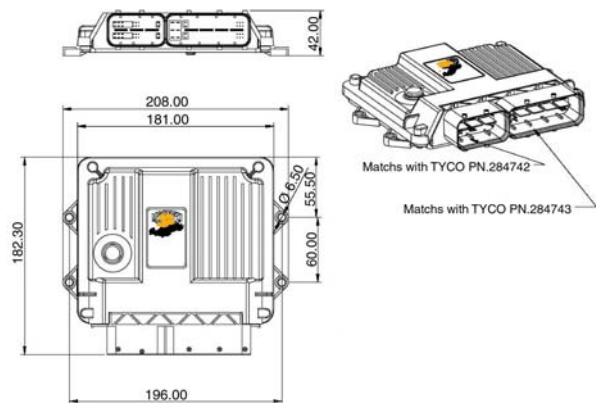

Dimensions in millimetres

Application Schematics

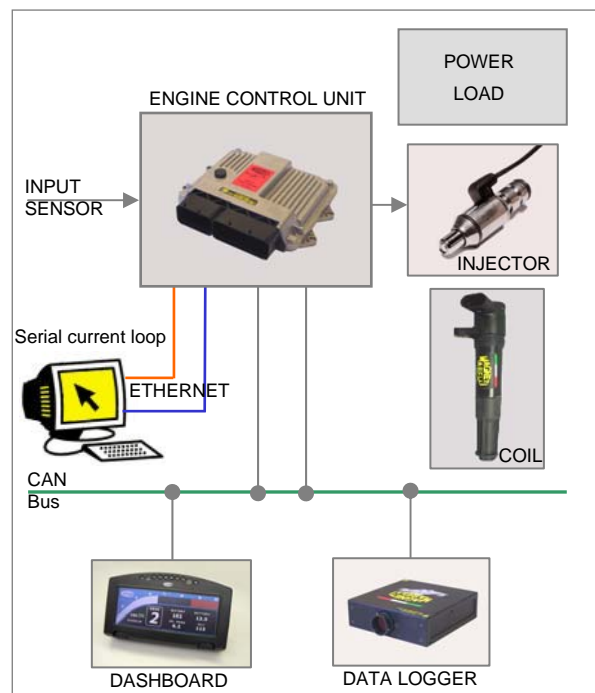

SRA-E-0838XXXXXXXXX000

For further information, please contact:



Magneti Marelli S.p.A.
Motorsport
Viale Aldo Borletti, 61/63
20011 Corbetta (Milano) Italy

Tel. +39 02 972 27 478
Fax +39 02 972 27 570
sales@magnetimarelli.com
http://www.magnetimarelli.com

May 2010
rel. 10
page 2 of 2