

ENGINE CONTROL UNIT

SRT-E

Professional engine control
High performances

Description

SRT-E is an evolution of the SRA Engine Control Unit with greater input/output and communications capability in a reduced package size and having more robust external connections.

SRT-E is a dedicated Engine Control Unit. A single SRT-E can drive up to eight injectors and six ignition coils. It is compatible with a wide range of sensors and actuators (especially F1 products) such as coils, injectors and sensors. SRT-E can also drive logic command coils (HW option).

Communication from the PC based configuration tool and to other units (such as dashboard and logger) is possible by 2 CAN lines and an asynchronous serial line.

Inside the unit there is a high performance RISC microcontroller and an FPGA for diagnostic purposes.

SRT-E provides analogue inputs for single-ended, temperature and knock-sensor as well as an interface for a linear wide band lambda sensor. The unit also provides 2 H-Bridge output stages for use with suitable "Drive by Wire" or Trumpet Control actuators.

6 configurable speed sensor inputs (up to 3 inductive) provide full flexibility of configuration for engine angle detection as well as other frequency inputs such as wheel or shaft speed.

SRT-EDL is a version of the SRT-E Engine Control Unit with an internal 32 or 64 Mbyte data logger.

It's available the DIM-141, an external Magneti Marelli module, to manage GDI and Diesel applications.



Main Features

- 14 Single-ended
- 3 Pick-ups or Hall effect
- 3 Hall effect
- 6 Inductive or logic command ignition drivers (HW option)
- 8 On/Off injector drivers
- 2 H-Bridge: DC-Motor driver for "Drive by Wire" control
- 4 PWM
- 2 Linear Lambda
- 2 Knock input for detonation control accelerometers
- 2 CAN communication buses
- 1 Ethernet line

Benefits

- Accurate engine control by means of high computation power
- Compatible with F1 products (injectors, coils, sensors, etc.)
- The logic command coils option is available on request
- SW selectable NTC/PT1000 temperature sensors
- Floating point data management
- Direct management of Marelli dashboard display
- Compatible with a wide range of professional software tools
- Introduced circular connectors
- Very compact design and easy to install

Typical Applications

Professional circuit and rally applications
One make race series

ENGINE CONTROL UNIT

SRT-E

Professional engine control
High performances

Technical Characteristics

Inputs

Analogue Single-ended	14
Linear Lambda sensor.....	2
Knock sensor	2
K-type thermocouple	2
NTC/PT1000 temperature sensor (selectable).....	4
NTC internal temperature sensor.....	1
V battery injector	1
VR Pick-ups or Hall effect.....	3
Hall effect	3
Lap trigger	1
“Code Load” enable pin	1
Syncro (Iso9141)	1

Outputs

On/Off injector drivers.....	8
Inductive or logic command ignition drivers (HW option)..	6
H-Bridges	2
Lambda heater drivers.....	2
PWM	4
Voltage references	3

Communications

CAN line (1 Mbit/s (*)).....	2
Ethernet line (100 Mbit/s)	1
Serial current loop	1

(*) Configurable on request

Logic Core

Microcontroller (80 MIPS RISC).....	1
FPGA (50k gates).....	1
Flash E2PROM (microcontroller)	1 Mbyte
RAM memory (microcontroller).....	48 Kbyte
RAM memory	512 Kbyte
E2PROM.....	64 Kbyte
Time keeper	1

Other Characteristics

Power supply.....	7 to 16 V
Operating temperature range (internal).....	-20 to 85 °C
Protection class.....	IP 54
Dimensions	
without connectors	134 x 132 x 39 mm
Weight (approx.).....	700 g

Dimensions

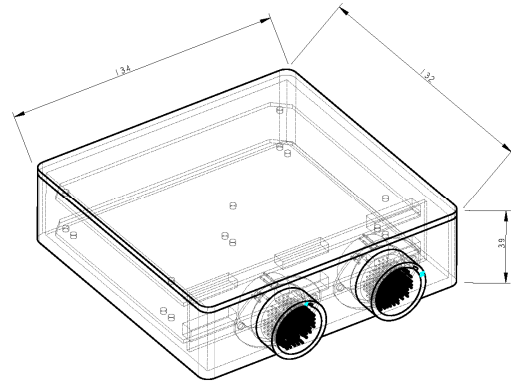

Dimensions in millimetres

Application Schematics

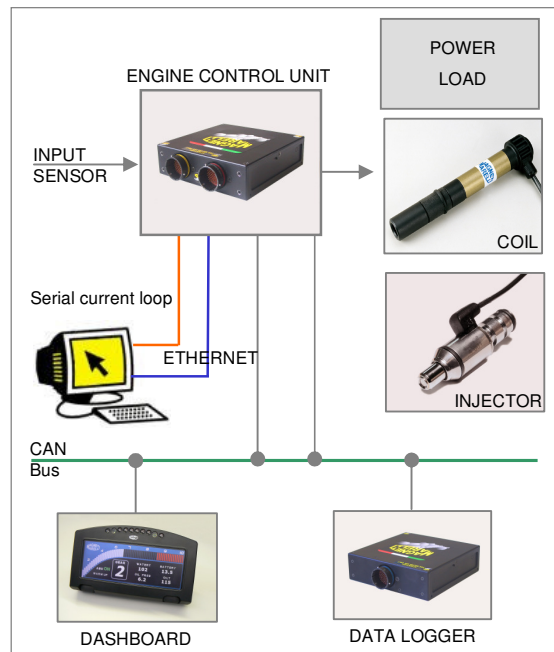

For further information, please contact:



Magneti Marelli S.p.A.
Motorsport
Viale Aldo Borletti, 61/63
20011 Corbetta (Milano) Italy

Tel. +39 02 972 27 478
Fax +39 02 972 27 570
sales@magnetimarelli.com
http://www.magnetimarelli.com

May 2011
rel. 13
page 2 of 2