

BAE801

Double ended ignition coil

Description

A compact high energy cost effective double ended ignition coil for inductive ignition systems to be used with std. ignition modules.

Particularly suitable for four cylinder engines with “wasted spark” arrangement.

Main Features

- Simple ignition system design mainly on 4 cylinder engines

Benefits

- Low cost

Typical Applications

Atmospheric and blown engines

F3 - IRL – GT - Rally



IGNITION COILS

BAE801

Double ended ignition coil

Technical Characteristics

Nominal supply voltage.....	12 V
Charge current.....	6 A
Dwell.....	< 3.5 ms
Rise time.....	< 19 μ s
Sec. Voltage (under 1 M Ω).....	> 25 kV
Spark duration.....	2.1 ms
Combustion energy.....	60 mJ
Connector type.....	Minitimer 3 ways
Weight.....	403 g

Application Schematics

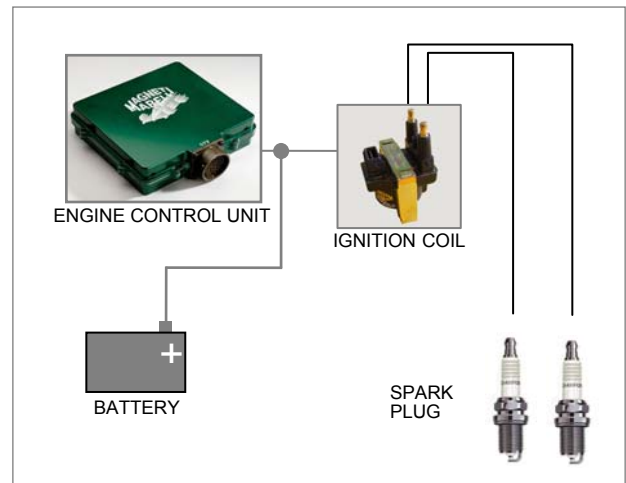

Dimensions

Dimensions in millimetres

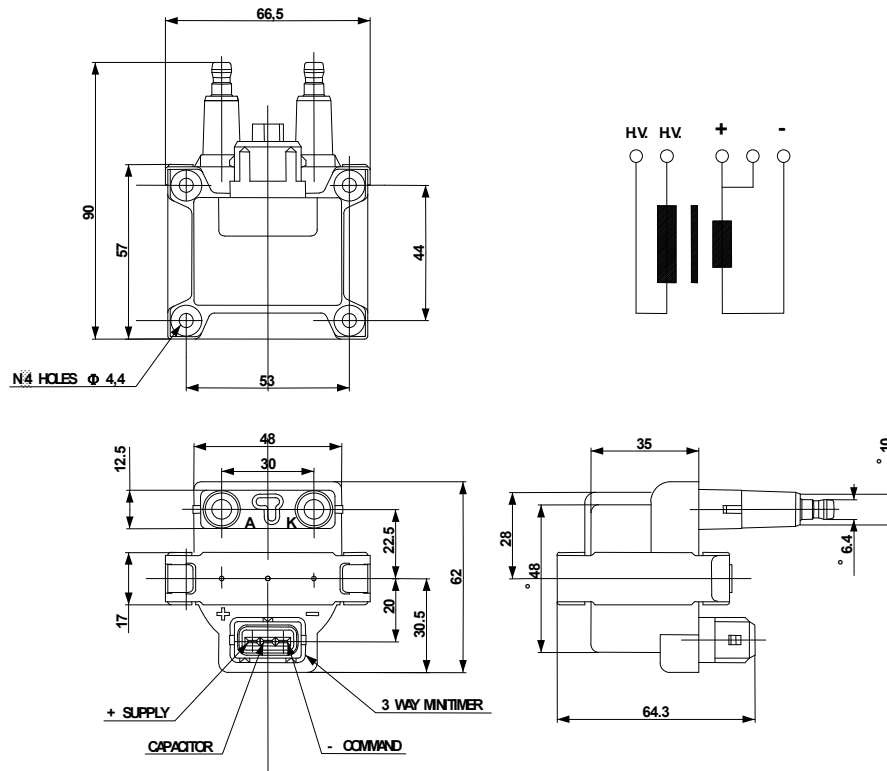

For further information, please contact:



Magneti Marelli S.p.A.
 Motorsport
 Viale Aldo Borletti, 61/63
 20011 Corbetta (Milano) Italy

Tel. +39 02 972 27 478
 Fax +39 02 972 27 570
 sales@magnetimarelli.com
 http://www.magnetimarelli.com

March 2009
 rel. 06
 page 2 of 2