

## PRESSURE REGULATORS

### GPR

High performance for racing injection systems  
0.5 to 3 MPa - 25 to 600 L/h

#### Description

GPR fuel pressure regulator has been developed to meet the market requirements for a cost effective regulator for high performance racing injection systems.

It combines good precision, high flow handling capability, little dimension and fast response.

The GPR design can be installed on the engine or in the tank assembly.

The regulator can be used also with supercharged engines.

#### Main Features

- Fast response
- High precision
- Good integration
- Can be installed on the engine or in the tank

#### Benefits

- Small dimensions
- Low weight
- Cost effective solution

#### Typical Applications

IRL

In circuit and rallies application

Race motorcycle application



#### Typical Performance

REGULATION CURVE

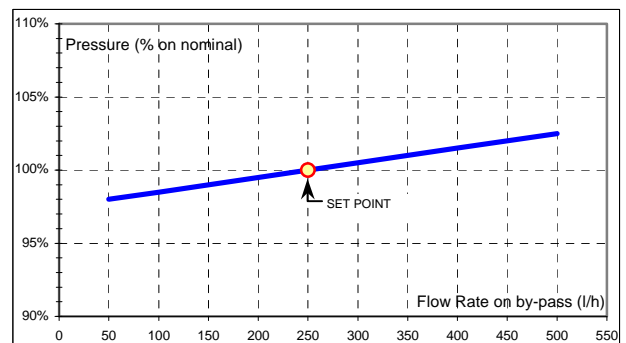

# PRESSURE REGULATORS

## GPR

High performance for racing injection systems

0.5 to 3 MPa - 25 to 600 L/h

### Dimensions

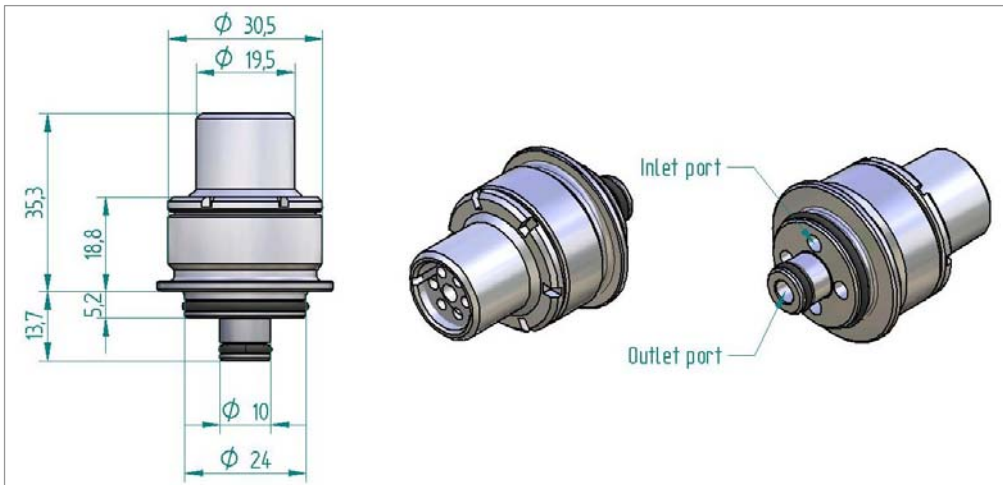

Dimensions in millimetres

### Technical Characteristics

- Set up pressure range ..... 0.5 to 3 MPa
- Flow range ..... 25 to 600 L/h
- Regulation slope ..... < 0.01 %/(L/h)
- Max. vibration (peak) ..... 60 g
- Temperature range ..... -10 to 110 °C
- Fuel ..... commercial, methanol and F1
- Weight ..... < 60 g

### Application Schematics

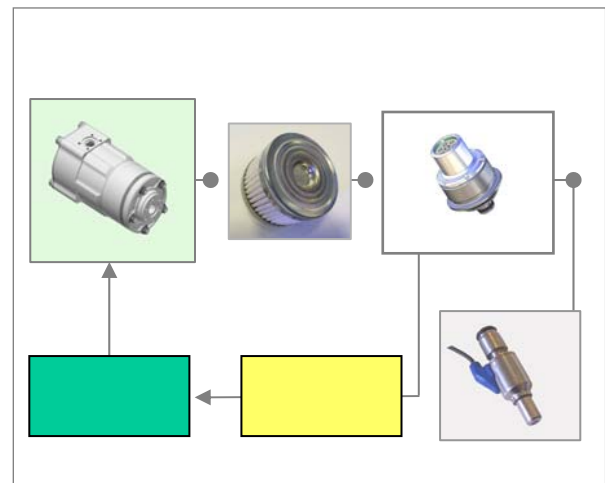

### GPR Family

Fuel pressure regulator	GPR001.1	GPR002.1	GPR003.1	GPR004.1	GPR005	GPR006.1	GPR008	GPR009	GPR010	GPRT01	
Nominal pressure	500	1000	2000	3000	800	3000	1500	600	1000	600	kPa
@ Flow rate	250	60	60	250	250	60	60	250	105	200	L/h

For further information, please contact:

GPR-0838XXXXXXXXX00



**Magneti Marelli S.p.A.**  
 Motorsport  
 Viale Aldo Borletti, 61/63  
 20011 Corbetta (Milano) Italy

Tel. +39 02 972 27 478  
 Fax +39 02 972 27 570  
 sales@magnetimarelli.com  
 http://www.magnetimarelli.com

November 2010  
 rel. 04  
 page 2 of 2