

IWP

Pico Top Feed Racing Injector
Up to 0.5 MPa - Up to 0.66 L/min

Description

The IWP "Pico" top feed injector is a standard production component, tested and selected for racing applications.

The characteristics of the injector are a fast pulse response, high precision, high dynamic range and optimum fuel atomization. These are achieved by a high performance ON-OFF actuating electromagnet with opposing expansion poles that moves an internal injector valve on high-precision ground cylindrical slides, and a high precision nozzle.

The injector has a stainless steel body, a fuel-resistant plastic connector, martensitic stainless steel internal valve and an electromagnet with a low carbon content stainless steel armature.

The electrical connection to the control unit is via a Mini-Timer plastic plug.



Main Features

- Pressure range 0.3 to 0.5 MPa
- Static flow range 0.33 to 0.66 L/min
- Driver current 0.8 A
- Spray shape single spray or twin jet

Benefits

- Methanol
- Multihole spray shaping
- On off driven
- High precision
- Small dimension & weight

Typical Applications

In professional circuit and rally applications
Touring car

INJECTORS

IWP

Pico Top Feed Racing Injector
Up to 0.5 MPa - Up to 0.66 L/min

Technical Characteristics

Pressure range	0.3 to 0.5	MPa
Static flow range	0.33 to 0.66	L/min
Driver current	0.8	A
Spray type	multihole	
Spray shape	single spray or twin jet	
Power supply	8 to 16	V
Operating temperature range.....	-30 to 110	°C
Connector type.....	AMP Junior 2 ways minitimer	
Weight.....	35	g

Dimensions

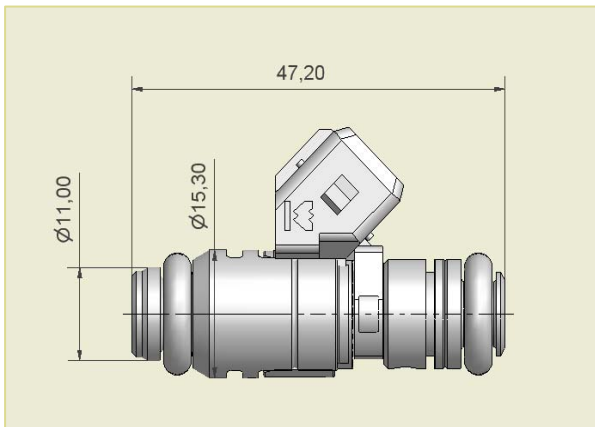

Dimensions in millimetres

IWP Family

Injector	IWP043	IWP063	IWP145	IWP069	IWP162	IWP189	
Nominal pressure	500	500	500	300	400	300	kPa
Static flow rate	421.1	498.3	658	482,5	377,2	510,5	cm ³ /min
Spray shape	Single spray	Twin jet	Twin jet	Single spray	Single spray	Cone spray	

Application Schematics

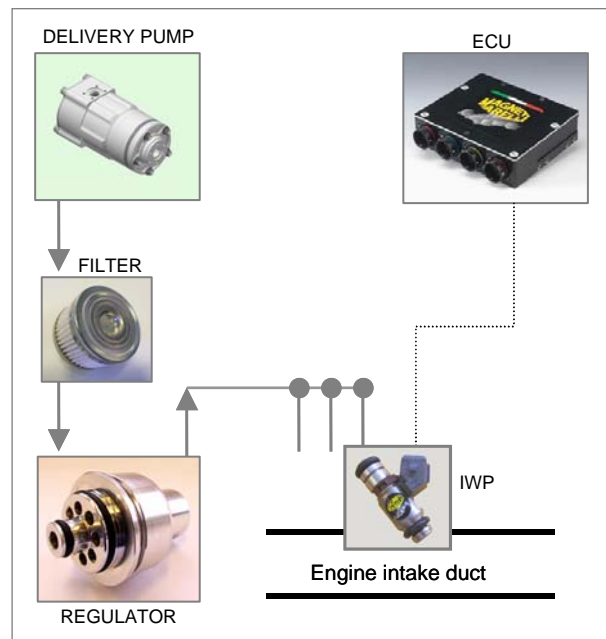

For further information, please contact:

IWP-0638XXXXXXXXX00



Magneti Marelli S.p.A.
Motorsport
Viale Aldo Borletti, 61/63
20011 Corbetta (Milano) Italy

Tel. +39 02 972 27 478
Fax +39 02 972 27 570
sales@magnetimarelli.com
http://www.magnetimarelli.com

November 2010
rel. 06
page 2 of 2