

## RPT350-RS

350° Rotary position transducer  
round shaft

### Description

The RPT350-RS, with a measurement range of 350 degree, is a rotary position transducer designed for racing and automotive applications.

Black glass filled nylon case and stainless steel shaft with Raychem FDR type 55 - AWG22 cable.

Resistant to high temperature, fire, chemical, RPT350-RS is particularly suited in the harsh automotive environment.

The user can adjust the cable length (max 1 m) for his application and this can be done contacting the company.

A RPT version with push shaft (RTP350-PS) is available.



### Main Features

- Resistant to high temperatures, fire and chemical
- Cable length to customer requirement
- Shaft in stainless steel
- Case in black glass filled nylon
- High strength and durability

### Benefits

- Wide application range
- Lightweight design
- High reliability
- Designed for rugged applications

### Typical Applications

Angle position measurement (throttle position, gear position, etc.)

# RPT350-RS

350° Rotary position transducer  
round shaft

## Dimensions

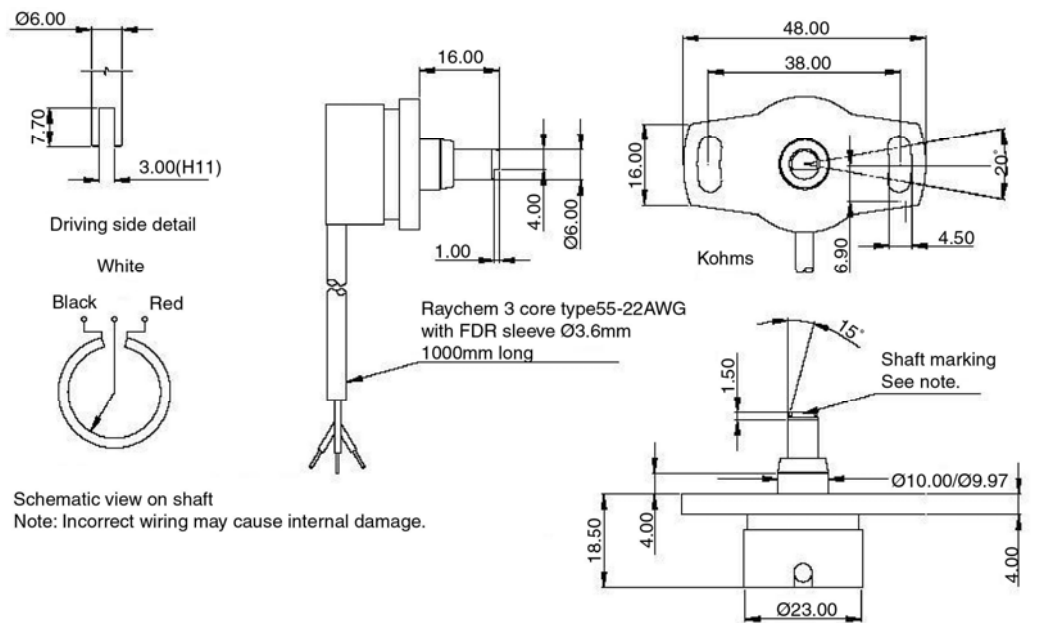

Schematic view on shaft  
Note: Incorrect wiring may cause internal damage.

Dimensions in millimetres

Note: When shaft marking is facing cable exit, instrument is mid-travel.

## Technical Characteristics

Electrical angle.....	350°
Nominal resistance ( $\pm 20\%$ ).....	5 k $\Omega$
Max applied voltage.....	42 V
Max wiper current.....	1 mA
Independent linearity.....	$\pm 0.3\%$ f.s.
Operating temperature range.....	-55 to 125 °C
Insulation resistance @ 500 Vdc.....	> 100 M $\Omega$
Mechanical travel (continuous).....	360°
Protection class.....	IP 65
Weight (approx.).....	38 g

## Connector Pin Out

Wire colour table	
Red	Supply voltage
Black	GND
White	Signal

For further information, please contact:



**Magneti Marelli Holding S.p.A.**  
Motorsport  
Viale Aldo Borletti, 61/63  
20011 Corbetta (Milano) Italy

Tel. +39 02 972 27 478  
Fax +39 02 972 27 570  
sales@magnetimarelli.com  
http://www.magnetimarelli.com

October 2007  
rel. 02  
page 2 of 2