

# WTS 05

3 kΩ Water Temperature Sensor

## Description

The WTS 05 is a low cost analogue temperature sensor with an NTC sensing element.

## Main Features

- Mini-Timer connector
- Fast response time

## Benefits

- High signal level
- Low cost

## Typical Applications

Touring cars water-oil temperature measurement



## Typical Performance

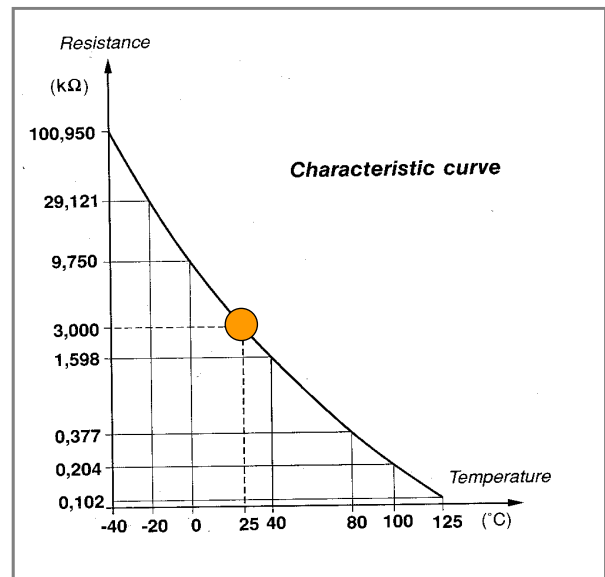

# WTS 05

3 kΩ Water Temperature Sensor

## Dimensions

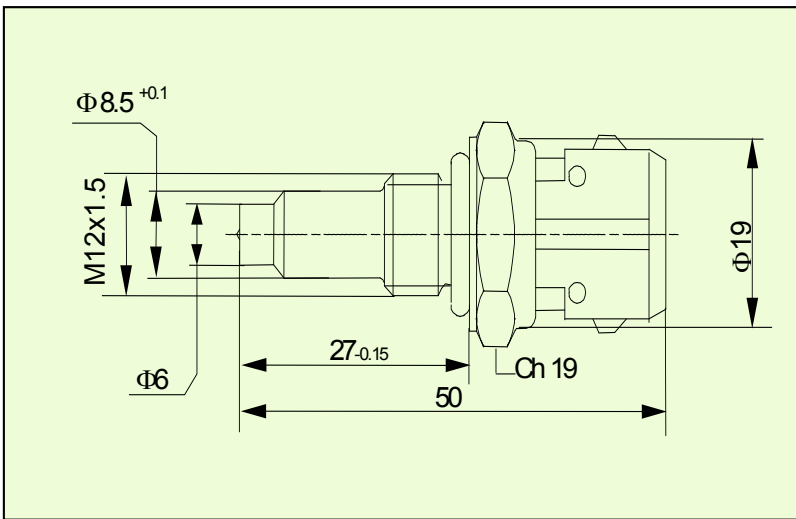

Dimensions in millimetres

## Technical Characteristics

Resistance (@ 25 °C).....	3	kΩ
Input voltage .....	5	V
Accuracy from nominal values		
@ -40 °C to 125 °C.....	5	%
Connector (2 ways).....	Mini-Timer	
Weight.....	26	g

## Application Schematics

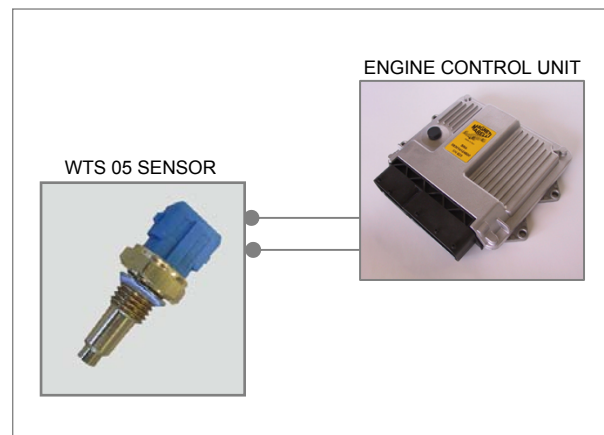

For further information, please contact:

WTS 05-083800242000



**Magneti Marelli Holding S.p.A.**  
 Motorsport  
 Viale Aldo Borletti, 61/63  
 20011 Corbetta (Milano) Italy

Tel. +39 02 972 27 478  
 Fax +39 02 972 27 570  
 sales@magnetimarelli.com  
 http://www.magnetimarelli.com

November 2007  
 rel. 05  
 page 2 of 2